

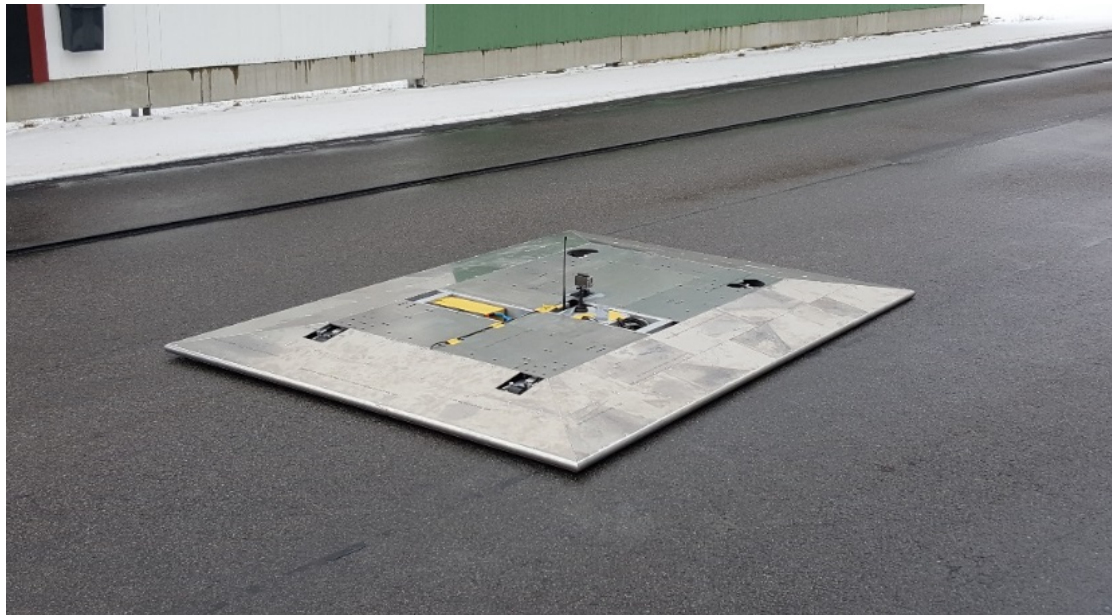

FORDONSSTRATEGISK
FORSKNING OCH INNOVATION

Final report, A-TEAM phase 2a



Writers: Niklas Lundin, Christian Berger, Magdalena Lindman, Per Gustafsson, Anna
Wriqe Berling, Mats Petersson, Håkan Andersson, Henrik Gillgren
Date: 170413
Sub program: Vehicle Safety

Contents

1	Executive Summary	4
2	Background	5
3	Purpose.....	5
4	Project realization.....	5
4.1	WP1, project management	6
4.2	WP2, State-of-the-art in testing of active safety systems and requirements specification for the infrastructure.....	6
4.3	WP3, accident scenarios	8
4.4	WP4, method development for light vehicles	8
4.5	WP5, method development for heavy vehicles.....	9
4.6	WP6, test equipment demonstrator	9
4.7	WP7, quality assessment and repeatability analysis	10
4.8	WP8, mid-speed target carrier and artificial road edge.....	10
5	Results and deliverables	10
5.1	Results per work package	10
5.1.1	WP2	10
5.1.2	WP3	11
	Light vehicle accident scenarios	11
	Literature review.....	11
	Analysis of crash data	13
	Heavy vehicle accident scenarios	13
	Same direction - heavy truck turning across VRU path:.....	14
	Straight crossing path – VRU from left or right:	15
5.1.3	WP4	16
5.1.4	WP5	17
5.1.5	WP6	18
5.1.6	WP7	22
5.1.7	WP8	22
5.2	Delivery to the FFI goals	23
6	Dissemination and publications	24
7	Conclusions and future research	24
8	Participating parties and contact persons	25



FORDONSSTRATEGISK
FORSKNING OCH INNOVATION

9 References 26

9.1.1 Appendix 1. List of published reports on Run-off road real-world crash characteristics..27

FFI in short

FFI is a partnership between the Swedish government and automotive industry for joint funding of research, innovation and development concentrating on Climate & Environment and Safety. FFI has R&D activities worth approx. €100 million per year, of which half is governmental funding. The background to the investment is that development within road transportation and Swedish automotive industry has big impact for growth. FFI will contribute to the following main goals: Reducing the environmental impact of transport, reducing the number killed and injured in traffic and Strengthening international competitiveness. Currently there are five collaboration programs: **Vehicle Development, Transport Efficiency, Vehicle and Traffic Safety, Energy & Environment and Sustainable Production Technology.**

For more information: www.vinnova.se/ffi

1 Executive Summary

To reach Vision Zero and maintain the competitive edge of the Swedish automotive cluster, research into active safety is crucial. The Swedish automotive cluster also has an ambition to be better than the level that laws and rating, such as EuroNCAP, require. To realize research and development of novel active safety functions to address situations far more reaching than what is required by these organizations, dedicated research activities are needed into new test methods to support the development of the new systems and functions to preserve leading market positions for the Swedish automotive industry.

A-TEAM phase 2a targeted, through research, the development of four method packages for important scenarios where research and development is needed for active safety systems. Further three work packages focused on the test system. The research about methods took place in work packages WP3, WP4, 5 and 7. WP3 performed research into scenario definition for light and heavy vehicles. WP4 focused research on light vehicles and developed methods for vulnerable road users (VRUs), intersection scenarios and run-off-road. WP5 focused on heavy vehicles through research on methods for vulnerable road users and multiple vehicle situations. The third method related package, WP7, focused on quality and reliability analysis of the developed methods.

Concerning the test system WP2, 6 and 8 have focused on future test system requirements, state-of-the-art assessments, and development vital test system components.

To summarize the following has been delivered by A-TEAM 2a:

Light vehicles

- Method for cyclist, Rating level TRL6
- Method for cyclist, beyond Rating level TRL4
- Method for left turn with traffic head-on TRL5

Heavy vehicles

- Heavy truck turning across VRU path TRL4
- Straight crossing path – VRU left/right TRL4

Test system components

- Test system requirements TRL2
- New target carrier TRL6
- Mid-speed target carrier TRL6
- Artificial road edge TRL4

2 Background

Because of the rapid technical development, the number of potential active safety functions has increased at brisk pace. To be able to develop and verify these functions all the way to production-ready solutions, a host of new test methods and test systems is needed. The functions of today mainly address accidents between vehicles in the most common rear-impact situations, but accident types with a high number of injuries such as accidents with cyclists, heavy vehicles, and at intersections are not sufficiently addressed yet. Thus, methods to test these types of situations does not yet exist and thus, a test system is also missing that would fully support the complete variety of velocities, angles, and precision needed to conduct the testing contained in A-TEAM phase 1. Existing equipment is in many cases technically immature and not integrated with other sub systems, something that has been confirmed in AstaZero's and the project team's initial benchmark analysis. Because of the lacking integration, only low efficiency regarding time and resource is possible, something that is already hampering the development rate for active safety systems for the Swedish automotive industry. In A-TEAM phase 1, a pre-study mapping the overall need regarding methods, equipment, and the like was included.

The state-of-the-art for active safety testing is in many ways similar to that of passive safety testing in the seventies and it is clear that the group that first researches the test methods and test systems needed to develop and validate the next generation of active safety systems gets a great competitive advantage. A clear example is EuroNCAP where the rating for intersections and cyclists is aimed to be introduced in the 2018-2020 time frame.

3 Purpose

A-TEAM phase 2a aimed at continuing the work started in A-team phase 1 within three various scenario types with the research associated to these steps: the methods themselves, the test system, and field data research. The method research also aims to allow the Swedish automotive cluster to develop systems and functions far ahead of the current state-of-the-art, making it possible to maintain and strengthen the world-leading position of the cluster.

4 Project realization

The project was divided into eight work packages, WP1 to WP8. This section is an introduction to the realization of each work package.

4.1 WP1, project management

WP1 was the project management work package. In this work package, the various other work packages were followed up on a weekly basis with respect to results, reporting, coordination, economy, and others. Reporting, planning of demonstrations, and project prioritizing were also part of the tasks of WP1.

4.2 WP2, State-of-the-art in testing of active safety systems and requirements specification for the infrastructure

The goal of phase 2 in WP2 is to identify requirements for the infrastructure to test active safety systems. To reach this goal, in A-TEAM phase 2a the state-of-the-art and future trends regarding testing processes (e.g., features of test-targets) were systematically investigated to support the realization of a flexible and extensible infrastructure.

Scoping Workshop to Determine Scope of WP2

To meet the stakeholders' needs, we systematically planned and conducted a scoping workshop with representatives from all WPs and discussed the planned methodologies in-use in WP2.

Literature Review on Testing of Active Safety Systems

Based on the outcome from the scoping workshop, we have planned and conducted a preliminary literature review, which only revealed a very limited amount of studies on testing of active safety systems, mostly related to EuroNCAP testing. From these numbers, we concluded that a systematic mapping study with a broader scope is necessary to meet scientific excellence. We are currently conducting such a systematic mapping study, using well-established guidelines of Petersen et al. [4], focusing on the entire area of autonomous vehicles. Up-to-date we have defined the research methodology for this study in a structured way (e.g., search string, data bases, research questions, filtering of papers) that has been already critically reviewed involving several researchers and project partners.

Automation of topic extraction to Support Literature Review

Furthermore, we are conducting a study on how to use machine learning techniques to support the analysis of the topics covered by the papers on autonomous vehicles. This will allow us to analyze a huge amount of papers on autonomous vehicles and to extract relevant information.

State-of-the-art and Future Trends of Active Safety Testing (internal project partners)

To explore the industrial state-of-the-art and future trends on testing processes of active safety testing, we followed the guidelines from Shull et al. [3] and conducted a qualitative study involving relevant representatives from the Swedish industry. We conducted four workshops including eleven project-internal partners from VCC, AB Volvo, Autoliv, AstaZero, and SP.

We designed our on-site workshops in a structured way so that it would include the OEMs as well as suppliers to get the different angles on the domain. Furthermore, we based our design of the workshops on the existing results from the pre-study planned and conducted in A-TEAM phase 1.

Our on-site workshops consisted of four different parts (structured in part i and part ii):

- i. State-of-the-practice in testing of active safety systems
 1. State-of-the-practice in EuroNCAP testing
 2. Passive vs. active safety testing
 3. Designated questions derived from pre-study on challenges of active safety testing (content of A-TEAM phase 1)
- ii. Future trends (concerning automation) affecting testing of active safety systems

Each workshop was conducted by two researchers: one researcher moderating the workshop and the other researcher taking notes of the workshop content by transcribing the discussed topics.

This transcript is used for the analysis of workshops. Due to the exploratory nature of the workshops, we applied coding on the transcripts, which then were further analyzed and an understanding of the studied topic developed [1][2]. This coding helps in clustering the content into topics. Furthermore, we applied word analysis to find most common words in the transcripts. This helped us as well in the analysis and summary of the most important concepts discussed during the workshops.

State-of-the-art and Future Trends of Active Safety Testing (international focus)

We made a plan for the extension of our state-of-the-art and future trends study with an international focus. We have designed a questionnaire that will be used to collect data from international collaborators to include a holistic view on the testing processes of active safety testing.

Design of Infrastructure

Based on our understanding of the testing processes that we gained from the state-of-the-art study, we will present a requirement specification for the testing infrastructure. We have started with two additional studies on the synchronization/collaboration of test targets to execute a test scenario involving several automated actors:

1. Integration of drive files from different vehicles to the new platform developed in A-TEAM. The goal is the development of a tool that would allow you to choose drive files from VCC, Autoliv, or Anthony Best Dynamics and transfer the information to the format of the new platform.
2. Synchronization of test platforms to the VUT. The execution of test scenarios requires all test platforms and the VUT to follow certain drive patterns, which are usually described in position and time format. Due to uncertainties (e.g., delays) for example of the VUT, the conditions described by a scenario will not be

fulfilled and the test will have to be run again. We have started with a study that would synchronize the test platforms involved in different scenarios to the VUT. Hence, for example in case the VUT accelerates, then the platforms should accelerate as well.

4.3 WP3, accident scenarios

The goal for WP3 was to, based on traffic accident data, identify relevant accident scenarios and also specify these for the development of test scenarios, see Figure 1.

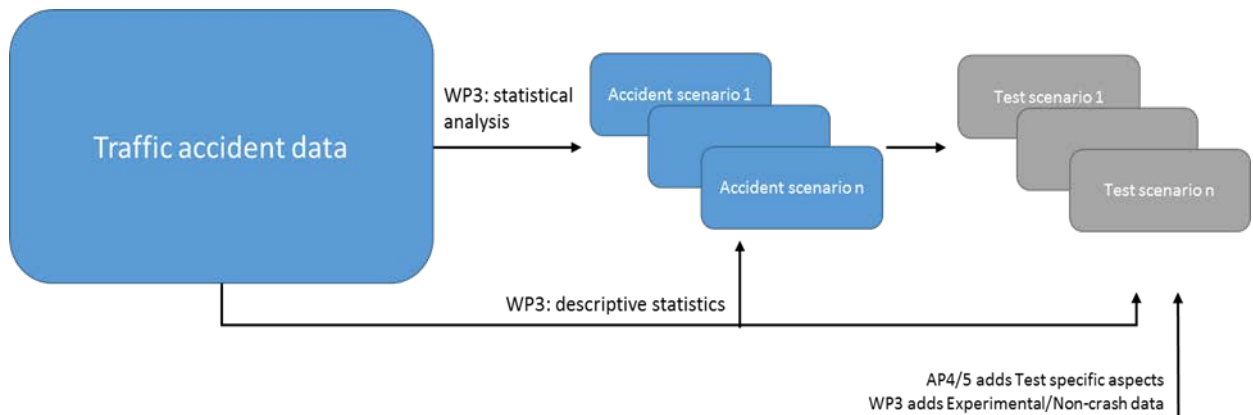

Figure 1. Illustration of substeps in WP3.

Accident scenarios for the conflict situations:

- Run-off road,
- Truck-VRU (Vulnerable Road User – pedestrians and bicyclists)

were identified and handled in A-TEAM phase 2a. Each accident scenario formed the foundation for a test scenario. Then, data analysis supplemented the specification of each test scenario that was defined later in WP 4-5.

4.4 WP4, method development for light vehicles

Research of a test platform for testing has been performed without the driver in the loop, for cyclist, intersection scenarios, and for run of road scenarios. This included test scenarios, test methods, test objects with propulsion system, driving robots, measurement equipment etc. The work is based on input from WP3, where a number of test scenarios were identified for the relevant scenarios.'

In parallel a test platform has been developed for system testing with the driver in the loop in Run off Road scenarios in a ViP (Virtual prototyping and assessment by simulation) financed project. These tests have been conducted at AstaZero in parallel with the tests without the driver in the loop in A-Team.

4.5 WP5, method development for heavy vehicles

WP5 is parallel to WP4, but with the difference that it targets method development for heavy vehicle scenarios.

Research of a test platform for testing without the driver in the loop has been performed, for cyclist and pedestrian scenarios (“Same direction – heavy truck turning across VRU path” and “Straight crossing path – VRU from left or right”). This included test scenarios, test methods, test objects with propulsion system, driving robots, measurement equipment etc. The work is based on input from WP3, where a number of test scenarios were identified for the relevant scenarios.

4.6 WP6, test equipment demonstrator

WP6 included a benchmark activity to establish the capabilities of state-of-the art, as well as development of a new target carrier.

The goal of the benchmark task has been to assess the capabilities of existing equipment for testing active safety functions. Such equipment includes driving robots, propulsion systems for target dummies, and the dummies themselves. The result is a gap analysis, i.e. an identification of a possible mismatch between current equipment and present as well as upcoming test methods and procedures. Among the parameters that have been assessed are:

- Positioning performance, i.e. the capability to be at the correct position at the correct time
- Dynamic performance, e.g. acceleration and deceleration capability, turning performance and top speed
- Handling performance, e.g. set-up time and turnaround time
- Environmental performance, e.g. coping with adverse weather conditions and low temperatures

So far the following equipment has been fully or partly assessed:

- Pedestrian rig ABD SPT
- Pedestrian rig 4a
- EuroNCAP target, EVT including propulsion with ABD robot-controlled tow vehicle
- Vehicle platform, ABD GST
- ABD driving robot (steering, throttle, and brake)

The main goals of the target carrier are: 90mm tall, top speed of 80km/h, withstand rain and moist, safe to run over with passenger car or truck and high efficiency testing by offering low downtime between consecutive tests and easy transportation between test locations. The thorough work in the early phase of the project, i.e. the designing phase of the target carrier, should result in only minor alterations and/or additions to the design of

both the mechanical as well as the electrical aspect of the target carrier. This in turn should result in an efficiently constructed target carrier.

The maximum height criterion of 90mm of the target carrier greatly affected the availability of components capable of handling the rest of the criteria. Finding components suitable for the target carrier required many new personal connections to be made. Several small companies were involved in delivering the components required and almost every mechanical component was produced in-house. Close collaboration between mechanical engineer, workshop technicians and external suppliers has been performed. The collaboration should result in equipment which has great chance of driving at top speed of 80km/h in rainy weather conditions while withstanding a run-over scenario by a heavy truck.

4.7 WP7, quality assessment and repeatability analysis

Developed test methods have to be precise in their formulation to allow for repeatable execution. Further there are many components, which are independent of the specific test method, which have to be in place to allow for repeatable tests. WP7 has focused mainly on test method generic components which are vital, such as an efficient and precise positioning process.

4.8 WP8, mid-speed target carrier and artificial road edge

WP8 covered iterative development and assessment of necessary test system components required by WP4, and 5. Specifically a mid-speed target carrier, primarily designed to pull targets in longitudinal trajectories in front of a vehicles path at speeds up to 60 km/h. Necessary target carrier platforms were also included. Further, road edge targets, with the goal to simulate a road edge on e.g. high speed area where developed and evaluated.

5 Results and deliverables

5.1 Results per work package

5.1.1 WP2

Deliverable 1: Talk at AstaZero Researchers' Day

We have presented our design of the state-of-the-art and future trends at the AstaZero Researchers' Day 2015-10-14.

Deliverable 2: Preliminary Report on Testing Processes

In November 2015, we have delivered a preliminary report on the testing processes, explored in the state-of-the-art and future trends study. This report included results from 2 of the 4 interviews.

Deliverable 3: First publication on State-of-the-Art and Future Trends [5]

We have published a first paper on our study of the state-of-the-art and future trends including the analysis of all four workshops conducted with the project-internal partners. It is published at the International Workshop on Software Engineering for Smart Cyber Physical Systems, which is co-located with the International Conference on Software Engineering (ICSE) and will be presented in May 2016 in Austin, Texas.

5.1.2 WP3

In WP3, the accident scenarios for selected conflict situations were identified in traffic accident data. Also, statistical analysis specified the scenarios for test development in WP4-5.

Light vehicle accident scenarios

Literature review

Published reports that studied Run-off Road accidents or Run-off Road situations in driving data in real traffic were reviewed, and their results were compiled per groups of Pre-crash-factors relating to the driver, velocity-related measures, traffic environment and to the vehicle. Examples of relevant information for the project was the relevance of the variety in carriageway width, curve radius, road surface etc from crash data and details such as departure angle and speed at departure from driving data. A list of the reports can be found in Appendix 1. In a Swedish study [6], more than 3000 crashes on median-separated roads, were combined with road geometry and -surface data. It was stated that road characteristics affect crash rate, large radii right-turn curves are more dangerous than left curves and that motorway carriageways with no or limited shoulders have the highest crash rate. Run-off road crashes in US was analysed using the National Motor Vehicle Crash Causation Survey [7]. The most influential factors in the occurrence of single-vehicle ROR crashes were the factors “driver inattention,” “driver was fatigued,” and “driver was in a hurry” – hence motivating driver-in-the-loop testing. In [8] special focus was given to run-off road crashes on ramps, that frequently occurred when vehicles were exiting highways at night, in bad weather, or on curved portions of ramps. In a number of studies, Accident- and Test Scenarios based on different crash databases were defined. In [9], police reported crashes were used. Five scenarios for light- and heavy vehicles, respectively, were recommended, see Figure 2.

Table 21. Recommended Run-Off-Road Crash Imminent Base Test Scenarios for Light Vehicles and Heavy Trucks

No.	Light Vehicle (Host Vehicle)	Heavy Truck (Host Vehicle)	Schematic
1	Light vehicle is going straight at 25-55 mph and departs road edge to the right in daylight or darkness, clear weather, on straight and level road.	Heavy truck is going straight at 25-55 mph and departs road edge to the right in daylight, clear weather, on straight and level road.	
2	Light vehicle is going straight at 30-60 mph and departs road edge to the left in daylight or darkness, clear weather, on straight and level road.	Heavy truck is going straight at 25-55 mph and departs road edge to the left in daylight/ darkness, clear weather, on straight and level road.	
3	Light vehicle is negotiating a curve at 30-55 mph and departs road edge to the right in daylight or darkness, clear weather, on sloping road.	Heavy truck is negotiating a curve at 30-55 mph and departs road edge to the right in daylight, clear weather, on sloping road.	
4	Light vehicle is negotiating a curve at 40-60 mph and loses control in daylight, clear or adverse (i.e., slippery surface) weather, on sloping road.	Heavy truck is negotiating a curve at 35-55 mph and loses control in daylight, clear weather, on sloping road.	
5	Light vehicle is turning left at 25-45 mph and departs road edge to the right in daylight, clear weather, on straight and level road.	Heavy truck is turning left at 20-40 mph and departs road edge to the right in daylight, clear weather, on straight and level road.	

Departing right road edge
 Departing left road edge
 Control loss

Figure 2. Test Scenarios based on US police reported crashes, ref Najm and Smith, 2006 [9].

German insurance data was used to identify 5 lane departure Accident Scenarios [10], see Figure 3a and 3b.

	Scenario 1	Scenario 2	Scenario 3	Scenario 4	Scenario 5	
Relevance and brief description						
Filter criteria for assignment to a scenario						
Road surface	Dry	Dry	Damp/wet	Damp/wet	Damp/wet	
Course of the road	Bend	Straight	Straight	Straight	Bend	
Radius of the bend	≥ 200 m	-	-	-	≥ 200 m	
Light conditions	Daylight	Daylight	Daylight	Dawn/darkness	Daylight	
Severe weather conditions	None	None	None	Heavy rain	None	
Additional information						
Relevance in relation to all accidents (n=100)	n	27	23	7	6	5
	%	27	23	7	6	5
Relevance in relation to all fatalities (n=32)	n	12	2	3	3	1
	%	38	6	9	9	3
Average speed of the case car	85 km/h	90 km/h	75 km/h	Unknown	70 km/h	

Figure 3a. Lane Departure Accident Scenarios based on German insurance data, ref Kühn et al, 2015 [10].

Scenario	Percent age (n=100)	Location	Typical lane width	Typical speeds	Lowest speed	Highest speed	Type and location of the road markings		Typical collision opponent and direction of the lane change before the collision	Average age of the drivers (only cases with a known cause)	Typical driver-related causes for inadvertent lane departure	Average age of drivers with health problems	
							Left	Right					
S1	27	Rural roads	2-3 m	86 km/h	45 km/h	160 km/h	Left	Broken	Car	To the left	59	Health problems (45%), distraction/inattention (38%), overfatigue (9%), drugs (9%)	72
						Right	Continuous						
S2	23	Rural roads	2-3 m	91 km/h	50 km/h	140 km/h	Left	Broken					
						Right	Continuous						
S3	7	Rural roads	3-4 m	68 km/h	40 km/h	90 km/h	Left	Both					
						Right	Both						
S4	6	Both urban and rural roads	2-3 m	100 km/h (one case)			Left	Broken			22	Overfatigue (75%), alcohol/drugs (25%)	-
							Right	Continuous					
S5	5	Rural roads	2-3 m	67 km/h	50 km/h	90 km/h	Left	Broken			48	Health problems (25%), overfatigue (25%), distraction/inattention (25%), severe weather conditions (25%)	25
							Right	Continuous					

Figure 3b. Specification of Lane Departure Accident Scenarios based on German insurance data, ref Kühn et al, 2015 [10].

Analysis of crash data

Volvo Cars Traffic Accident Data (VCTAD) was analyzed to provide input based on Swedish run-off road crash characteristics to the Test scenario development. Non-loss-of-control run-off road crashes in straight roads with recent Volvo car models, model years later than 1999, that occurred during accident years 2007 to 2013 was selected.

Descriptive statistics showed that for run-off road crashes, the most common..

- posted speed limit was 70-90 km/h
- lane markings are dashed (not solid) when departure to the right
- driver's estimated speed was 60-100 km/h
- light condition was daylight, although darkness held a significant portion of the crashes

Further, a cluster analysis defining Accident Scenarios was performed and the Run-off Road Accident Scenario recommended based on this, is a crash on a straight road where the passenger car initially travels in 70 km/h in the rightmost lane (width ~3.5 m) in the travel direction. The car departs to the right with departure angle (vs the road) 4° or 8°.

Heavy vehicle accident scenarios

Studies presenting accident data analysis of heavy truck accidents involving pedestrians or bicyclists were compiled.

Same direction - heavy truck turning across VRU path:

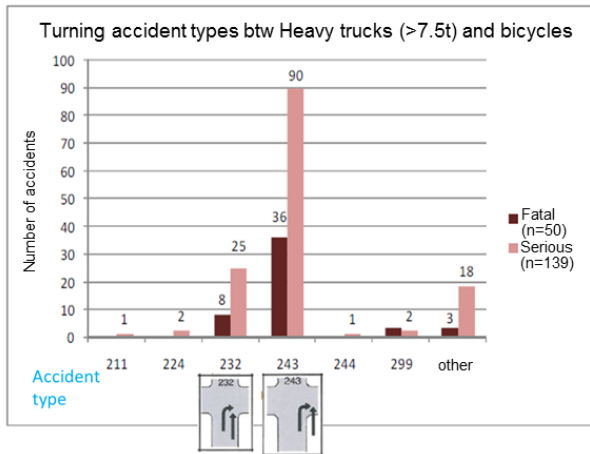

Accident type distribution

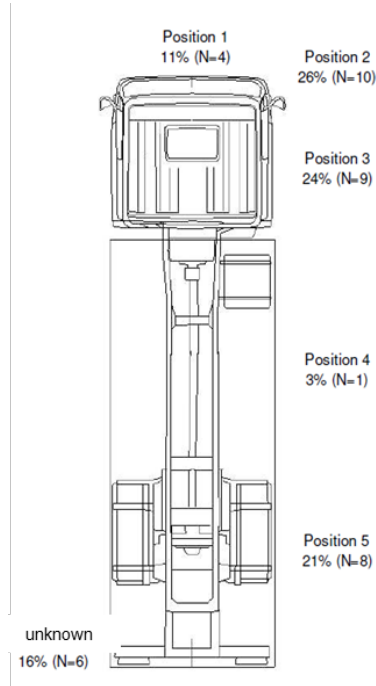

Impact point on truck

Figure 4. Accident type distribution and impact point on truck in turning accidents with bicycles based on German accident data, ref Schrek et al, 2014 [11].

Summary of accident conditions [11]:

- Urban area
- Daylight
- Dry weather
- Both with and without traffic light signaling
- Initial speed of heavy truck is below 30 km/h (in 90 % of cases)
- Initial speed of bike is below 20 km/h (in 85% of cases)
- In 40% of cases, initial speed of bike is larger than speed of the heavy truck, partly caused through truck starting from stationary and cyclist catching up from behind.
- Bike does not brake in 65% of cases
- Heavy truck does not brake in 70% of cases
- Driver did not see cyclist in 90% of cases

Based on this, the following preliminary test scenario characteristics were defined for WP5:

- Assume truck movement to be first straight, then turning with constant radius
- Daylight and dry weather

- Parameters:
 - Speed heavy truck: 10, 20, 30, 40 km/h
 - Speed bicycle: 10-25 km/h
 - Lateral separation of truck and bicycle before turning: 1.5 to 4,5 m
 - Curve radius: 5m, 10m and 25m (radius of inner front wheel of heavy truck)
 - Point of impact at truck, distance behind truck front: 0 – 6 m
- For “Same direction – host vehicle turning” scenarios involving pedestrians, the only parameter that will be changed is the speed of the VRU.
 - Speed pedestrian: 1-10 km/h

Straight crossing path – VRU from left or right:

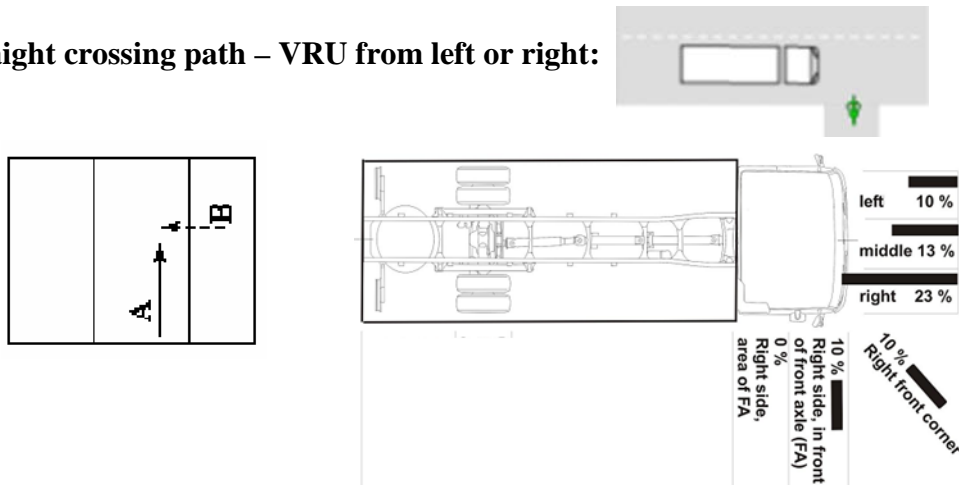

Figure 5. Accident type and impact point on truck based on German accident data, ref Desfontaines et al, 2008 [12].

Summary of accident conditions [12]:

- Urban area
- Daylight
- Dry weather
- Both with pedestrian crossings and without
- Speed of heavy truck is below 50 km/h (in >90 % of cases)

Based on this, the following preliminary test scenario characteristics were defined for WP5:

- Truck movement straight
- Daylight and dry weather
- Parameters:
 - Speed heavy truck: 10, 20, 30, 40, 50 km/h
 - Speed pedestrian: 1-10 km/h
 - Speed bicycle: 10-25 km/h

VRU: Cyclist:Test Method for rating:

The test method has reached TRL 6 with tests of a verified test target and propulsion system. Verification tests was performed at ASTA 2015Q4.

The A-TEAM project has worked in parallel with research activity conducted in Europe; the CATS [13] project, led by TNO. Work performed in A-Team has been able to influence the EuroNCAP rating method for cyclist tests.

The EUNCAP test target, developed by The Austrian company 4A, is in the final verification loop 2016Q2.

Test Method beyond rating:

The test method beyond rating has been put on hold in A-Team phase 2a due to limitations in the test target robustness in LTAP/OD and on-coming scenarios.

The test method has reached TRL 4.

Intersection:LTAP/OD (Left Turn Across Path / Opposite Direction):

The test method has reached TRL 5. To reach TRL 6 it is needed a platform which is robust in interaction with the test vehicle in turning scenarios. Verification test in turning scenarios is planned for the HSP platform developed in A-Team 2b 2016Q2 and for the ABD platform 2016Q3.

A draft test method description has been delivered 2016Q1 and further test method development will be conducted when the platform is verified for the turning scenarios. The test platform has been integrated into the internal processes used for test scenario development in use by the partners, both for CAE-based test-scenario development and direct programming of steering robots.

The prognosis is to reach TRL 6 2016Q4, as part of A-team 2b.

LSS:Run off Road:

The test method developed in A-team without the driver in the loop has reached TRL 5 with a test vehicle equipped with an ABD robot. To reach TRL 6 will need to be developed and verified an artificial road edge to be used in tests on a test track.

The Run off Road test method development in A-Team Phase 2b will be conducted in parallel with the EUNCAP rating development which will start during 2016Q2.

The prognosis is to reach TRL6 2017Q1 when the artificial road edge is verified.

5.1.4 WP5

Target development:

In A-TEAM 2a two different targets have been used: Pedestrian rig ABD SPT and Vehicle platform ABD GST. Both have the limitation that they cannot withstand being run over by a heavy truck.

For the Vehicle platform ABD GST a structure was built so that the bicycle target could be mounted with a 1.5m offset to secure that the platform would not be run over even if the target was impacted.



Figure 6. Vehicle platform ABD GST with bicycle target mounted with an offset.

The Pedestrian rig ABD SPT was judged to not be strong enough to hold for the added torque if the target was mounted with an offset. Therefore, only lower speeds were tested so that the test driver was able to take over control and brake before impact. Further work will be done in A-TEAM 2b to find a solution that works also for higher truck speeds.

Scenario generation

All test scenarios were created in PreScan to make a first prioritization of scenarios and also to generate drive files for the driving robot and target carriers.

Same direction - heavy truck turning across VRU path

The test method developed in A-TEAM 2a has reached TRL 4 with a test vehicle equipped with an ABD SR30 robot and the Vehicle platform ABD GST. The reason for this is that there were extensive technical problems when testing with the Vehicle platform ABD GST (with the platform itself – not with the added offset structure). To reach higher TRL levels more testing is needed.

The same scenario has also been tested with the Pedestrian rig ABD SPT as target carrier. TRL 4 reached also here. To reach higher TRL levels a better target carrier solution should be developed. This will be taken care of in A-TEAM 2b.

Straight crossing path – VRU from left or right

For this scenario only the set-up with the Pedestrian rig ABD SPT has been used. The reason is both that the Vehicle platform ABD GST was not available when this scenario was tested and also that the main focus of this scenario is on pedestrians and then the speed of the Pedestrian rig ABD SPT is fully sufficient. As in the turning scenario, an ABD SR30 driving robot was used in the truck. TRL4 has been reached also here – but higher TRL levels are probably not possible to reach without developing a solution for the target carrier so that it works also for higher truck speeds (up to 50 km/h). With a target carrier solution that is safe to use with a heavy truck and more testing – TRL6 is expected to be reached in A-TEAM 2b.

5.1.5 WP6

Benchmark

Below follow some brief observations with respect to the in A-team 2a conducted benchmark assessments:

- Pedestrian rig ABD SPT
 - Fairly easy to set-up, short turnaround time as long as the target is not hit
 - Controller believes it follows the desired speed profile. However measurement show that this is not the case, see figure below.
 - Does not reach its state top speed of the platform

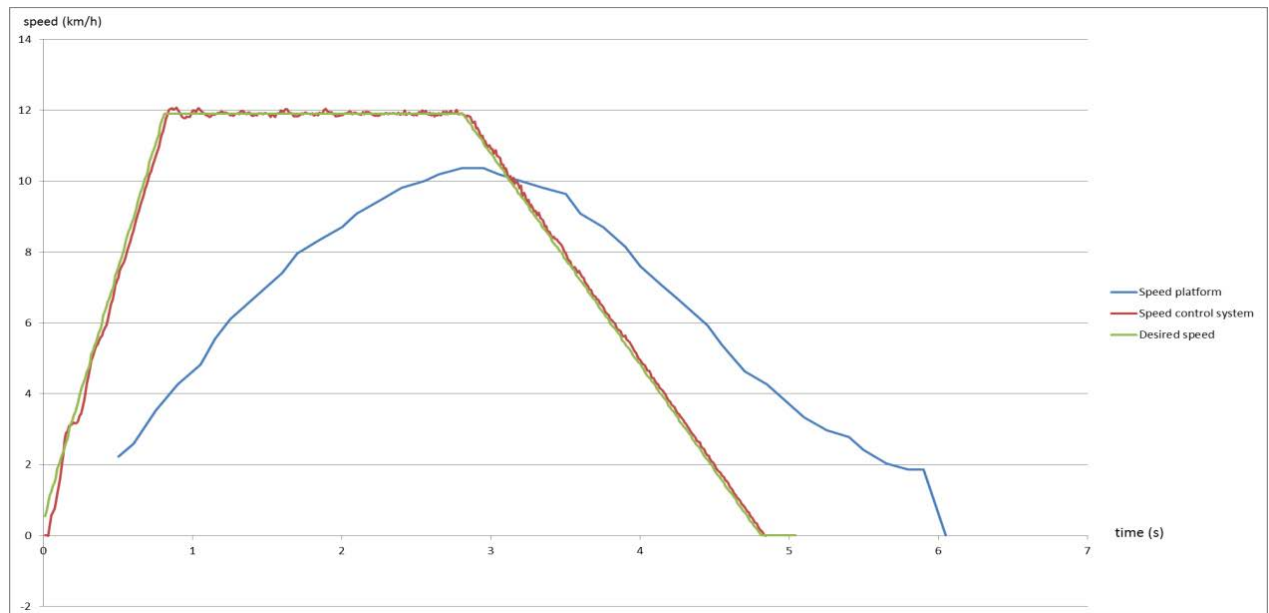

- Pedestrian rig 4a
 - Fairly easy to set-up, short turnaround time as long as the target is not hit
 - Have severe problems during wet conditions: some tests are aborted and stated top speed is not reached

- Acceleration and deceleration can be set in scenario program but do not affect the acceleration or deceleration in the actual test
- EuroNCAP EVT
 - Positioning and dynamic performance limited by the driving robot in the tow vehicle
 - Damping effect of the tow ladder must be further investigated. The target lags compared to the tow vehicle speed profile, see figure below.

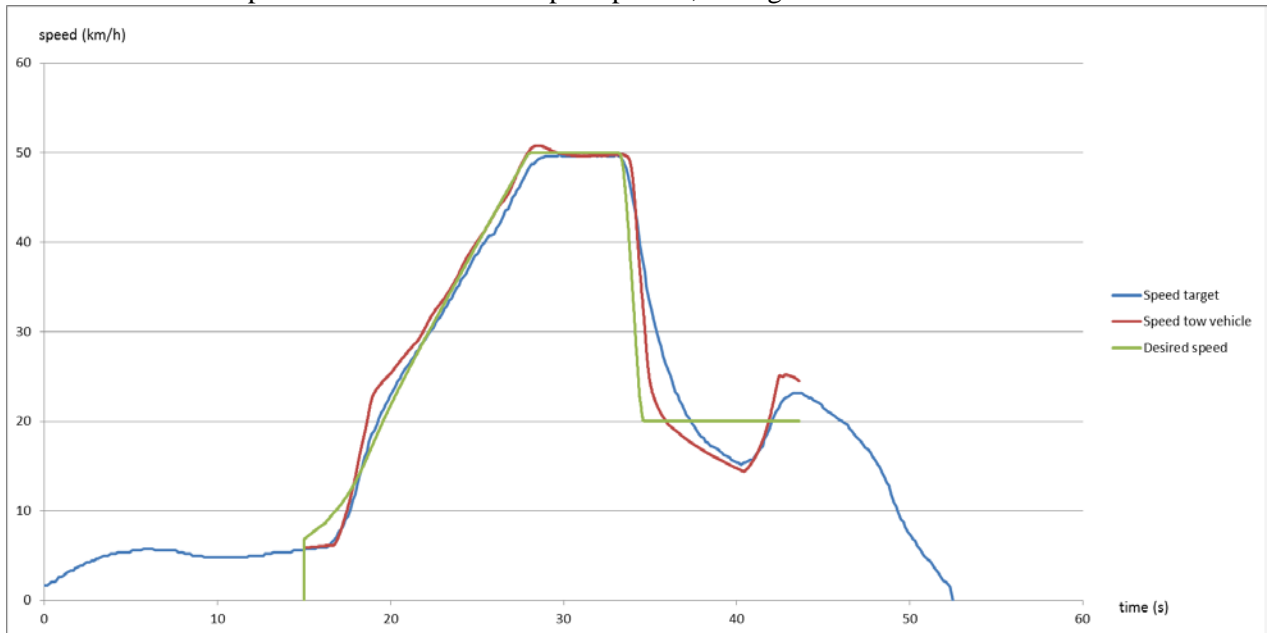

- Vehicle platform ABD GST
 - Assessment has been severely hampered by the GST capability to cope with wet and cold conditions
 - Further assessment is needed
- ABD driving robot
 - Assessment was performed using EuroNCAP AEB speed profiles
 - Given enough lead-in, the robot can perform tests with the speed, yaw, etc accuracy stated by the EuroNCAP test method

New platform

The preliminary design and overall specification of the target carrier was displayed at Researcher's day, 14th October 2015 at AstaZero. Visitors could ask questions and get more knowledge of what the A-TEAM project aims at producing in terms of test equipment. The display session included the foundation of the chassis, as well as a teaser video with specifications of the system.

The Mechanical design was completed and prototype production of parts was fully ongoing in October 2015. Design updates were continuously performed based on test

evaluation between October 2015 and April 2016. The final design is depicted in Figure 2 and consists of over 700 parts.

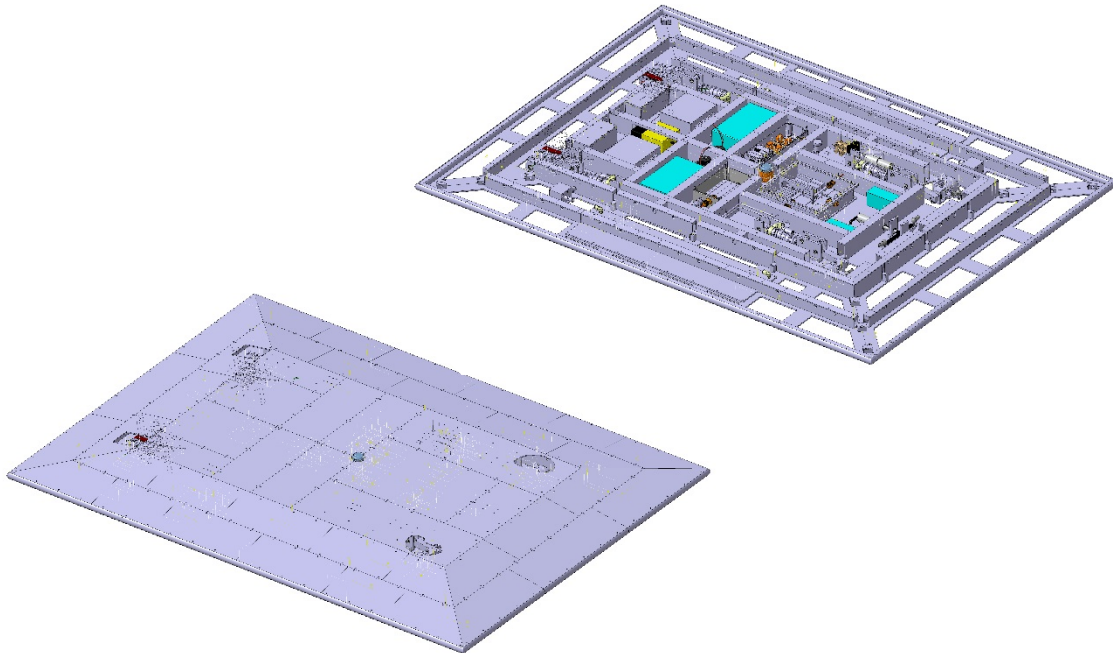

Figure 7 Depicting the CAD model of the target carrier developed in A-TEAM, with and without top plates.

In February 2016, the control system based on the NG-Test lowrider was integrated into the chassis of the target carrier. Figure 9 depicts the inside of the target carrier in the laboratory environment, ready for parameter tuning of all electrical components such as: brake actuation, steering response and precision, drive motor control, GPS acquisition, Accelerometer readings, water cooling system etc.

In March, the target carrier's steering and brake system as well as communication and emergency stop system was tuned and deemed ready for testing outside. Figure 10 shows a picture from the first test run of the target carrier. During this test run the maximum propulsion power of the target carrier was limited to approximately 3kW and it reached a velocity of approximately 30 km/h and the steering system worked as expected.

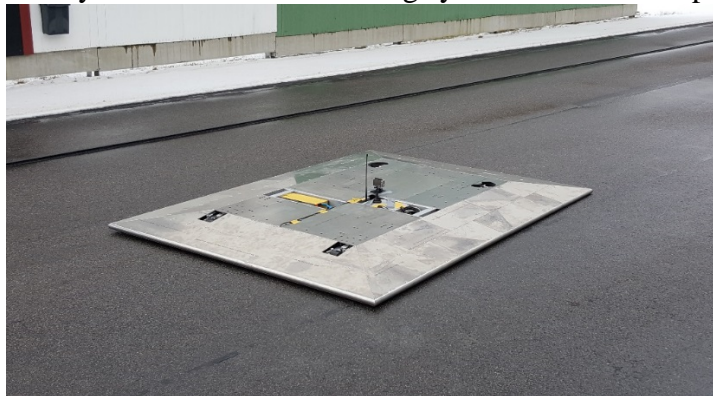

Figure 8 Depicting the target carrier assembled and ready for preliminary testing.

However, multiple problems arose when further testing began.

- Latency in the internal communication between different on-board systems led to poor responsiveness of the control commands; this was solved by adjusting the software.
- When the power limitation was turned off, the different parameters of the regulation system of the propulsion system proved to be set wrong which led to too high power output on the drive wheels which in turn led to wheel spinning and loss of control. The emergency stop was activated and due poor battery performance the propulsion battery system to one of the motors became damaged; this was solved by replacing the batteries and adjusting parameters of the regulation system.
- Furthermore, when the target carrier functioned as expected with low dynamics (i.e. low speed, small change of steering angle etc.) the system was set up to be tested with higher dynamics (i.e. more rapid change in acceleration, faster change of steering angle etc.). However, at the start of testing, when aligning the target carrier with the expected trajectory using the manual control the battery system was once again damaged. The probable cause was that the battery system could not handle the voltage/current spikes; the solution was to replace the batteries with another type of battery.
- New testing begun and as soon as the main contactors for the propulsion system was closed, the motor controller got damaged. The probable cause is an erroneous connection of the emergency stop system; the solution was to repair the motor controller and adjust the connection within the electrical system of the target carrier.
- Regarding mechanical performance of the target carrier, the drive belt cause the wheel axle to bend which in turn causes unnecessary wear of the drive belt due to the belt scraping at the sides of the drive belt pulley. The solution to be evaluated is adding a turnbuckle to rectify the wheel axle so that the belt does not slip to one side of the drive belt pulley thereby removing that type of belt wear.
- During that update to the target carrier, the size of the drive belt and drive belt sprockets was increased to increase performance of the belt drive system.
- Finally, the preliminary testing of the target carrier led to some wheel spinning which caused the rubber of the wheels to come off. During the update process new drive wheels with another type of rubber compound was also fitted.

The control system is yet to be adjusted and verified to function before the final functional prototype may be released and ready for method research testing within the A-TEAM project. This corresponds to TRL 6.

In A-TEAM 2b work will be focused on adjusting and verifying the control-, and electrical system followed by prioritized crash tests to evaluate whether it is ok for test driver to be exposed to the collision risk with the target carrier given a specific test scenario. The crash testing will be based on scenarios plausible to happen during the test methods to be performed. The velocity of the crash testing will start at low speed and will gradually be increase up to test scenario speed, this in order to ease the process of finding weak spots in the construction. Methods to be performed are LTAP/OD, cut-in scenario and head-on scenario with both passenger vehicle and heavy truck.

5.1.6 WP7

The following has been delivered as part of WP7:

- A rig and associated method has been developed to facilitate precise positioning of measurement equipment placed in vehicles.
- Efficient and precise GPS installation in test vehicles and its relative position to the vehicle's coordinate system. This is vital since the vehicle under test often is the reference for other objects, targets, vehicles, etc.
- Using LTAP, a WP4 test method, as a base a comprehensive evaluation has been performed, with approved results, to verify test equipment and test method repeatability and precision. During this evaluation scripts were developed to speed up test evaluation and report input.

5.1.7 WP8

The following has been delivered as part of WP8:

Prototype of a target carrier system for pedestrian, bicyclist and large animal targets with focus on high efficiency. The scenarios length is max 40 meters and the max target speed is 60 kph. The basic concept is two identical cable winches where one is master and one slave, working with a cable/line to which a tension is applied. At the time of A-team 2a closure final tests had not been performed, but the design concept has been verified to meet all major requirements. See figure below.



Figure 9: Prototype of mid-speed target carrier.

Further, in close cooperation with WP4, prototyping was performed on an artificial road edge target with the aim to test lateral support systems on e.g. high speed area. The prototype was based on different types of artificial grass which was rolled out on the tarmac. See figure below. During the work there was a EuroNCAP/CLEPA/ACEA workshop organized at IDIADA to evaluate this prototype and other similar ones. Unfortunately the end result was poor, the systems in the test vehicles could not reliably detect and identify the target as a road edge and the work had to be paused.



Figure 10: Artificial road edge target prototype.

5.2 Delivery to the FFI goals

The combination of a proving ground and the new tools and methods that this project aimed at developing contributes to many of the general FFI goals. Swedish industry has, thanks to the test methods, a unique platform for research and innovation and thus access to new tools in the work to remove accidents resulting in serious injuries and deaths. These test methods are needed also to support the development of autonomous vehicles since autonomous vehicles must be able to handle these situations.

The methods and test system addressed four out of six research areas in the strategic roadmap for the vehicle and traffic safety:

- Vehicle and traffic safety analysis including other facilitating technologies and knowledge
- Basic safety attributes of vehicles
- Driver support and related interfaces between driver and vehicle
- Intelligent collision-avoiding systems and vehicles

Through the mapping of the potential future method and test equipment steps, a plan was indirectly created for further contribute to the roadmap in many steps. Swedish vehicle industry is in the absolute cutting edge of active-safety development and the new possibilities in the new methods combined with the testing efficiency improvements will allow the industry to maintain and increase the leadership. Accidents in intersections are already mentioned as a domain where active safety can contribute [14]. Within this scope, cooperating systems based on vehicle to vehicle and vehicle to infrastructure is contained. As shown by Lefèvre [15], the number of involved parties in combination with their various types is increasing the dynamics and complexity of the traffic model. By using suitable warnings- or other active safety systems that e.g. informs parties in intersections in time, the associated risk for this traffic type can be lowered. The decision by EuroNCAP to develop a rating method for the scenario type further shows the focus dedicated to this traffic environment.

The increased method and equipment competence will allow the Swedish companies, institutes and universities to play a greater role in the EU Horizon 2020 programs. Within the SAFER framework, there is already a strong cluster that now has gotten more nourishment to further strengthen the cooperation between the triple helix parties. Swedish vehicle industry have gotten new possibilities to develop new vehicle based active safety systems that supports the driver in taking the right actions in situations involving various cognitive driver loading and possibility to strengthen driver initiated actions such as braking.

Similar scenarios will be designed for driving simulators and this will create a need to validate simulator tests using proving ground testing. The knowledge is used to develop driver models to CAE tools utilizing the potential of shorter development times of technology.

6 Dissemination and publications

From WP2, we gave a talk at AstaZero Researchers' Day in fall 2015 as well as one publication at the International Workshop on Software Engineering for Smart Cyber Physical Systems [5].

Experience concerning artificial road edge targets was disseminated through active participation in EuroNCAP's road edge workshop at IDIADA, Oct. 4-5, 2016.

Further, A-team 2a presented results at TSAF, FFI, result conference Sept. 21, 2016.

7 Conclusions and future research

A-TEAM phase 2a has delivered validated test methods, scenarios, test equipment prototypes and demonstrated them in test systems with performance levels necessary for validation of the methods. Research is continuing in A-TEAM phase 2b and through CHRONOS part 1. Work in WP2 has been vital as input to requirements in CHRONOS part 1.

Research into more scenarios, methods, equipment, and test infrastructure will continue in A-TEAM phase 2b. A number of other applications are also planned that originate from the ATEAM phase 1 WP2 pre study. CHRONOS part 2 and ATLAS are two examples of such applications.

8 Participating parties and contact persons



VOLVO



ASTAZERO
ACTIVE SAFETY TEST AREA



SAFER

Peter Janevik, peter.janevik@astazero.com, 010-5166143

Contact persons:

VCC: Anders Axelson, anders.axelson.ii@volvocars.com

AB Volvo: Anna Wrige Berling, anna.wrige@volvo.com

Autoliv: Per Gustafsson, per.gustafsson@autoliv.com

SP: Henrik Eriksson, henrik.eriksson@sp.se

Chalmers: Christian Berger, christian.berger@chalmers.se

AstaZero: Peter Janevik, peter.janevik@astazero.com, Niklas Lundin
niklas.lundin@astazero.com, Håkan Andersson, hakan.andersson@astazero.com

9 References

- [1] C. B. Seaman: *Qualitative Methods*. In Guide to Advanced Empirical Software Engineering, p. 35-62, 2008.
- [2] P. Runeson and M. Höst: *Guidelines for conducting and reporting case study research in software engineering*. In Empir. Softw. Eng., vol. 14, no. 2, pp. 131–164, Dec. 2008.
- [3] F. Shull, J. Singer, and D. I. K. Sjøberg, Eds., Guide to Advanced Empirical Software Engineering. London: Springer London, 2008.
- [4] K. Petersen, R. Feldt, S. Mujtaba, and M. Mattsson: *Systematic Mapping Studies in Software Engineering*. In Proceedings of the International Conference on Evaluation and Assessment in Software Engineering (EASE'08), pp. 68-77, 2008.
- [5] A. Knauss, C. Berger, H. Eriksson: *Towards State-of-the-Art and Future Trends in Testing of Active Safety Systems*. In Proceedings of the International Conference on Software Engineering for Smart Cyber-Physical Systems (SEsCPS'16), Austin, Texas, May 2016.
- [6] "Identifying Critical road Geometry Parameters Affecting Crashe Rate and Crash Type" Sarbaz Othman, Robert Thomson, Gunnar Lannér 2009 Oct 5
- [7] "Run-off-Road Crashes: an on-scene prespective" Cejun Liu, Ph.D., and Tony Jianqiang Ye July 2011
- [8] "Types and characteristics of ramp-related motor vehicle crashes on urban interstate roadways in Northern Virginia" Anne T. McCartt, Veronika Shabanova Northrup, Richard A. Retting 2003
- [9] Development of Crash Imminent Test Scenarios for Integrated Vehicle-Based Safety Systems (IVBSS) Wassim G. Najm and John D. Smith 2006
- [10] ANALYSIS OF CAR ACCIDENTS CAUSED BY UNINTENTIONAL RUN OFF ROAD Matthias Kuehn, Thomas Hummel, Jenö Bende 2015
- [11] Abbiege-Assistenzsystem für Lkw - Grundlagen für ein Testverfahren Benjamin Schreck, Dr. Patrick Seiniger 2014
- [12] PRUDENT-VI Project - PProtection of vulnerable road Users in case of acciDENT against an Industrial Vehicle, H. Desfontaines, P. Beillas 2008
- [13] O.M.G.C. Op den Camp, A Ranjbar, J Uittenbogaard, E Rosen, S.H.H.M. Buijssen, Overview of main accident scenarios in car-to-cyclist accidents for use

- in AEB-system test protocol. Proceedings of International Cycling Safety Conference, 2014, Göteborg, Sweden
- [14] U.S. Department of Transportation, National Highway Traffic Safety Administration: “The New Car Assessment Program Suggested Approaches for Future Program Enhancements”,
<http://www.safercar.gov/staticfiles/DOT/safercar/pdf/810698.pdf>.
- [15] S. Lefèvre: “Risk Estimation at Road Intersections for Connected Vehicle Applications”, PhD Thesis, Université de Grenoble, October 2012

9.1.1 Appendix 1. List of published reports on Run-off road real-world crash characteristics

"A Study of NMVCCS to Identify critical Pre-Crash Factor in Fatal Crashes" Mark Mynatt, James Bean, Charles J. Kahane, Carla Rush, Eric Traube, Chris Wiacek
"Identifying Critical road Geometry Parameters Affecting Crashe Rate and Crash Type" Sarbaz Othman, Robert Thomson, Gunnar Lannér 2009 Oct 5
"Understanding the Causation of single-Vehicle Crashes: a methodology for in-depth on-scene multidisciplinary case studies" Jesper Sandin, Mikael Ljung 2007
"Comparison of Factors Associated with Run-Off-Road and Non-Run-Off- Road Crashes in Kansas" Uttara Roy and Sunanda Dissanayake (Summer 2011)
"Run-off-Road Crashes: an on-scene prespective" Cejun Liu, Ph.D., and Tony Jianqiang Ye July 2011
"speed as Risk Factor in Serious Run-Off-Road Crashes: Bayesian Case-Control Analysis with Case SpeedUncertainty" GARY A. DAVIS, SUJAY DAVULURI, JIANPING PEI 2006
"EVALUATING CRASH AVOIDANCE COUNTERMEASURES USING DATA FROM FMCSA/NHTSA’S LARGE TRUCK CRASH CAUSATION STUDY" Kristin J. Kingsley

<p>"Single vehicle run-off-road accidents colliding turned down terminals of guardrails" E. Tomasch, H. Hoschopf, M. Gobald, H. Steffan, B. Nadler, F. Nadler, B. Strnad, F. Schneider</p>
<p>"Epidemiology of older driver crashes – Identifying older driver risk factors and exposure patterns" J. Langford , S. Koppel 2005-2006</p>
<p>"Types and characteristics of ramp-related motor vehicle crashes on urban interstate roadways in Northern Virginia" Anne T. McCartt, Veronika Shabanova Northrup, Richard A. Retting 2003</p>
<p>"Longitudinal Analysis of Fatal Run-Off-Road Crashes, 1975 to 1997" Richard McGinnis, Matthew Davis, Eric Hathaway</p>
<p>Rural Road Departure Crashes: Why is Injury Severity Correlated with Lane Markings? Kristofer D. Kusano, Hampton C. Gabler (Virginia Tech) January 2012</p>
<p>Crash Severity Analysis of Single Vehicle Run-off-Road Crashes Sunanda Dissanayake, Uttara Roy October 2013</p>
<p>Analysis of Run off Road Crashes in relation to Roadway Features and Driver Behavior Ertan Örnek, Alex Drakopoulos 2007</p>
<p>Effect of Rainfall and Wet Road Condition on Road Crashes : A Critical Analysis Mondal, P., Sharma, N., Kumar, A., Bhangale, U. et al., 2011</p>
<p>Factors Related to Fatal Single-Vehicle Run-Off-Road Crashes Liu, C., Subramanian, R 2009</p>
<p>SAFETY AND OPERATIONAL CONSIDERATIONS FOR DESIGN OF RURAL HIGHWAY CURVES. FINAL REPORT Glennon, J C, Neuman, T R, LEISCH, J E 1983</p>
<p>Development of Crash Imminent Test Scenarios for Integrated Vehicle-Based Safety Systems (IVBSS) Wassim G. Najm and John D. Smith 2006</p>
<p>Analysis of Run-Off-the-Road Crashes Involving Overcorrection Abhishek Mishra 2006</p>



FORDONSSTRATEGISK
FORSKNING OCH INNOVATION

<p>The Nature and Severity of Drift-Off Road Crashes on Michigan Freeways, and the Effectiveness of Various Shoulder Rumble Strip Designs David A. Morena 2002</p>
<p>SAFETY ASPECTS OF INDIVIDUAL DESIGN ELEMENTS AND THEIR INTERACTIONS ON TWO-LANE HIGHWAYS: INTERNATIONAL PERSPECTIVE Choueiri, Elias M, Lamm, Ruediger, Kloeckner, Juergen H, Mailaender, Theodor 1994</p>
<p>COMPARISON OF EVENT DATA RECORDER AND NATURALISTIC DRIVING DATA FOR THE STUDY OF LANE DEPARTURE EVENTS Kristofer D. Kusano, Rong Chen, Ada Tsoi, Hampton C. Gabler 2015</p>
<p>ANALYSIS OF CAR ACCIDENTS CAUSED BY UNINTENTIONAL RUN OFF ROAD Matthias Kuehn, Thomas Hummel, Jenö Bende 2015</p>
<p>Analysis of crash data to estimate the benefits of emerging vehicle technology. Anderson, R. W. G., T. P. Hutchinson, et al. 2011</p>