

Vehicle-ICT

The Vehicle Information and Communication Technology Programme

Project Descriptions

April 2008



SCANIA



VOLVO



The Vehicle IT and Telematics Programme – Vehicle-ICT

The Vehicle Information and Communication Programme (Vehicle-ICT) started in 2005 and runs until 2008. The programme partners are AB Volvo, Saab Automobile AB, Volvo Car Corporation, Scania CV AB, Västra Götaland Region (VGR), Business Region Göteborg AB (BRG), NUTEK and VINNOVA. The programme is managed by its board, with one representative from each party.

In December 2007, total Vehicle-ICT funds of approximately SEK 300 million will have been allocated to 26 projects¹. The financing comprises public funding of 125 million SEK from VINNOVA, NUTEK, BGR and VGR. Industry is thus providing slightly over SEK 175 million in funding.

The aim of the programme is to strengthen the international competitiveness of the Swedish Automotive Industry and create permanent R&D posts within the Vehicle ICT field. It also aims to strengthen expert knowledge in Automotive Electronics and Telematics, and bringing together the automotive and IT/ICT worlds.

More information on the background, aims and implementation of the programme appear in the full presentation (in Swedish) on VINNOVA's website.

Vilgot Claesson is leading the programme at VINNOVA.

¹ Excluding project brokerage and pre-studies.

Contents

Prestudy and Test Platform for the Integration of “Nomadic Devices” in Trucks	5
Unified Software Platform	5
Remote Diagnostics and Programming	6
Remote Diagnostics and Maintenance	6
OALDE – Open Arena Lab Demo Environment	7
ROBUST	8
MOZART – Model and Hardware In the Loop Simulator for Vehicles	8
SWiFT – Strategies for Wireless Communications Future Telematics Applications	10
SIGYN – Exchange of Diagnostic Information between Cars and Centralized Functions	10
VISAS – Volvos Infotainment Support Autolivs Safety	11
Secure & Reliable GPRS Connection on a Pan-European Basis	12
Methods for Development of E/E-Systemarchitectures in Early Phases	13
Model Management for Systems Engineering	13
ODI – Open Display Interface	14
DICO	14
VERA – Vehicle Electronics Reconfig on Aftermarket	15
Open Platform for Nomadic Devices	16
Efficient and Reliable Download of Digital Tacho Data	16
Flexible HMI Architecture	17
Automated Assistance Systems for Efficient Off-board Diagnosis	17
Common Product Model for Requirements Management and Model-based Development	18
NICT – The Network for Vehicle ICT Services for Test Site Sweden	19
SWAP – Software Automotive Platform	19
SimArch – a General Platform for Driving Simulators and Experiment Systems for Automotive Electronics	20
Value Driven Architecture Development	20
Robust Vehicle Data Communication	21

Prestudy and Test Platform for the Integration of “Nomadic Devices” in Trucks

Rec.no: 2005-01688

Project Manager: Nils-Gunnar Vågstedt

Duration: 2005-09-01 – 2005-12-31

Total Budget: SEK 1 400 000

Public Funding: SEK 700 000

Partner: Scania

The use of Nomadic Devices such as mobile phones, PDA:s, music players (t.ex. mp3) and navigators increase – this also in vehicles. The problem is that the integration to the vehicle in terms of driver interface, power supply and antennas is not optimized, and there is no overall solution. This project takes a small step towards trying to find a solution/strategy by:

1. Perform a small prestudy with focus on mobile phones in trucks.
2. Creation of test platform for various functions, incl. Bluetooth, in trucks.
3. Demonstrate telecom and audio streaming between Nomadic Devices and in-truck systems

The result of the project could be one input to a broader cooperation project within the area of “Nomadic Devices” within VICT.

Unified Software Platform

Rec.no: 2005-01700

Project Manager: Ingemar Söderlund

Duration: 2005-08-01 – 2007-07-01

Total Budget: SEK 23 259 000

Public Funding: SEK 5 814 750

Partner: Saab Automobile

The project shall lead to a standardized SW-platform for specification, development, test and documentation of SW based functionality for usage in all GM product lines.

The platform shall enable efficient SW development that will lead to substantially shorter time to production in combination with quality growth.

The platform shall enable:

- Sharing of SW between different products and product lines within GM.

- Integration of supplier developed/owned SW into GM owned SW
- Reuse of developed and tested SW
- Usage of standardized “Off the shelf” SW
- Hardware abstraction / hardware independence.

Remote Diagnostics and Programming

Rec.no: 2005-01703

Project Manager: Nils-Gunnar Vågstedt

Duration: 2005-06-01 – 2006-06-01

Total Budget: SEK 2 500 000

Public Funding: SEK 1 250 000

Partner: Scania

Increasingly more trucks are equipped with advanced telematics for Fleet Management. When the relevant components are in place a wide range of opportunities are opened, which would simplify the handling of trucks at the after market; typically remote diagnostics or even remote programming. This project will demonstrated on the Scania's fleet of test vehicles, in two steps:

1. Collection of fault codes
2. Setting of parameters

The result is a functioning system as well knowledge of how to utilize the possibilities of telematics. The project is a cooperation between Scania and Mecel and Mecel take the role as supplier in the project.

Remote Diagnostics and Maintenance

Rec.no: 2005-01715

Project Manager: Magnus Svensson, Volvo Technology

Duration: 2006-01-01 – 2008-12-31

Total Budget: SEK 10 623 700

Public Funding: SEK 5 312 850

Partners: Volvo Technology, Halmstad University

The project will as an application within the V-ICT program of Telematics and VehicleIT perform research and advanced engineering in the area of remote vehicle di-

agnostics and maintenance in order to increase up-time for commercial vehicles as well as to enable new services and business models. The final goal is to show a demonstrator with a predictive maintenance system that is able to on-line monitor the 'health' of a vehicle and signal before any serious problems occur.

We envision two novel things in the project: the on-board use of 'sensorimotor models' and information fusion from several vehicles to provide fleet learning.

OALDE – Open Arena Lab Demo Environment

Rec.no: 2005-02185

Project Manager: Hans Persson, Volvo Technology

Duration: 2005-03-15 – 2006-12-01

Total Budget: SEK 6 000 000

Public Funding: SEK 3 000 000

Partners: Volvo Technology, Ericsson Microwave Systems, Lindholmen Science Park

The transportation industries are facing new challenges as they are developing towards increased globalization and increased competition. To hold a competitive position, improved and cost efficient transportation solutions need to be developed. When developing these solutions one needs to consider information exchange and interfaces between driver, vehicle, transport management, society and infrastructure. In order to create these solutions, there is a need of setting up development environments where all these aspects can be considered.

The OALDE (Open Arena Lab Demo Environment) project has developed such an environment. Here different users and actors (both private and public) can develop and demonstrate new transportation services including logistics, safety and security aspects. This environment allows for concept development, simulations and demonstrations of vehicle to vehicle, vehicle to infrastructure and vehicle to back-office communications both to the private and public sector.

The project has been demonstrated, showing benefits and gains in a dangerous goods transport scenario, for several various stakeholders.

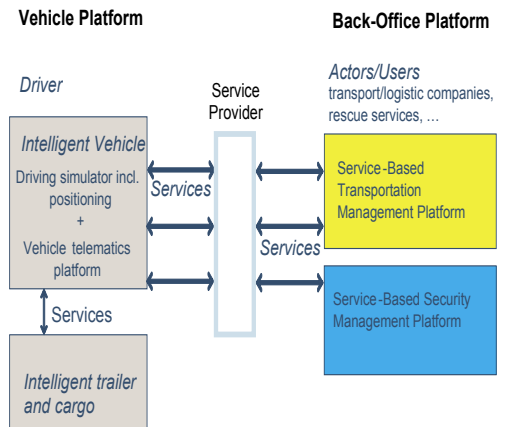

ROBUST

Rec.no: 2005-02188; 2006-02419

Project Manager: Fredrik Pettersson, Volvo Group

Duration: 2005-03-15 – 2009-12-31

Total Budget: SEK 15 446 006 (Phase 1); 9 011 000 (Phase 2)

Public Funding: SEK 7 723 003; 4 505 500

Partners: Volvo Group, Chalmers University of Technology

As telematics-based services become an integrated part of the vehicle software architecture, requirements on robustness need to be balanced against requirements on flexibility and openness. At the same time, the need to enable third party software to coexist with proprietary software in the same architecture is increasing, putting additional demands on the robustness of the software architectures.

Phase one of the ROBUST project resulted in a demonstrator platform for candidate technologies. Additional results included, among other things, an evaluation of a method for validating telematics software architectures with respect to robustness properties. The evaluation was performed in close collaboration between Chalmers and Volvo Technology.

Phase two of the ROBUST project aims to further strengthen academic and industrial competencies on how to establish, develop, quality assure and validate in-vehicle telematic software architectures and core services that fulfil the requirements on robustness. This involves studying how to elicit non-functional requirements related to robustness, how to design, implement, verify and validate robust software architectures, and developing a framework for validation of third party applications with respect to wanted properties. Additionally, the project aims to establish efficient ways to assimilate research results into product development in the rapidly changing area of telematics.

MOZART – Model and Hardware In the Loop Simulator for Vehicles

Rec.no: 2005-02196

Project Manager:

Martin Nilsson

Duration: 2005-12-01 – 2008-08-08

Total Budget: SEK 16 000 000

Public Funding: SEK 8 000 000

Partner: Volvo Cars

As complexity in vehicle electronics and functional distribution increases, tools for early verification of concept and solutions becomes more and more necessary. One step in this direction is realistic simulations of events controlled over the vehicle

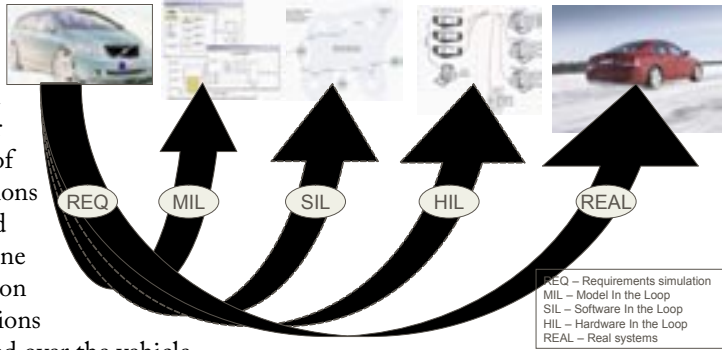

electrical architecture, e.g. a sensor for object identification which over the network contributes to speed regulation of the vehicle.

The aim is to R&D a simulation and test platform which is on-par with world leaders in simulation of electrical control functionality over the vehicle architecture covering all engineering domains, e.g. electrical, powertrain and chassis. The realization is carried out by Volvo Cars together with high-tech consulting firms.

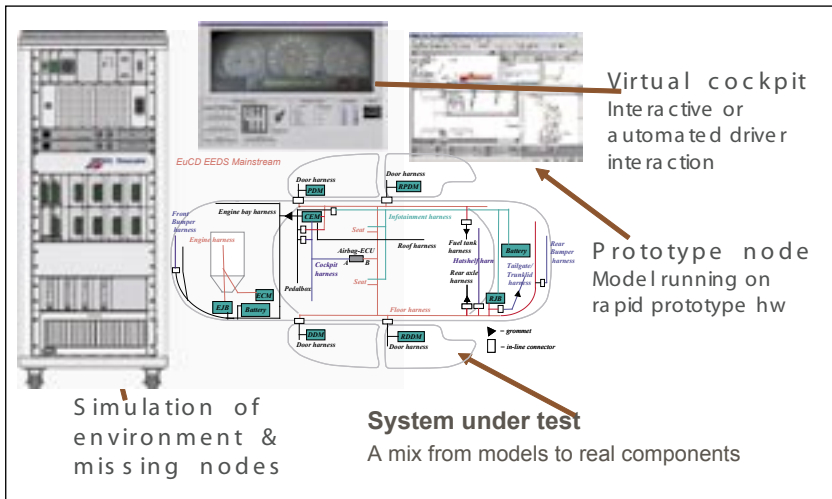

SWiFT – Strategies for Wireless Communications Future Telematics Applications

Rec.no: 2005-02200

Project Manager: Elisabeth Uhlemann, Volvo Group

Duration: 2006-03-16 – 2006-11-15

Total Budget: SEK 507 200

Public Funding: SEK 253 600

Partners: Volvo Group, Ericsson AB, Telia Sonera AB

Many of the technologies, products and services developed by the Volvo Group need or will need wireless access. Some of the communication requirements specific to telematics applications are different from that of the general user of wireless services. One purpose of SWiFT was to define which wireless technologies are best suited for future telematics applications and services given the specific application requirements. Another purpose was to initiate collaboration between the vehicle industry (represented by AB Volvo), the telecom industry (represented by Ericsson AB) and its service providers (represented by TeliaSonera). Within such collaboration, an overview of existing and planned future telematics systems, messaging strategies and wireless communication technologies can be compiled. Application specific problems can be identified and evaluated and research and development projects can be defined.

The goal is to provide incentive for further collaboration between the vehicle industry and the telecom industry.

SIGYN – Exchange of Diagnostic Information between Cars and Centralized Functions

Rec.no: 2005-02541

Project Manager: Kristina Bjelkstål, Volvo Cars

Duration: 2006-01-01 – 2008-08-08

Total Budget: SEK 22 000 000

Public Funding: SEK 11 000 000

Partners: Volvo Cars, Volvo IT, Chalmers University of Technology

Vehicle diagnostics and software download by the air enables fast and more precise fault tracing, statistics collected from the cars and software repairs. In the future this procedure can decrease work e.g. at workshops globally and provide access to all cars, not only cars at the workshops. The back-end functions are strengthened to manage and

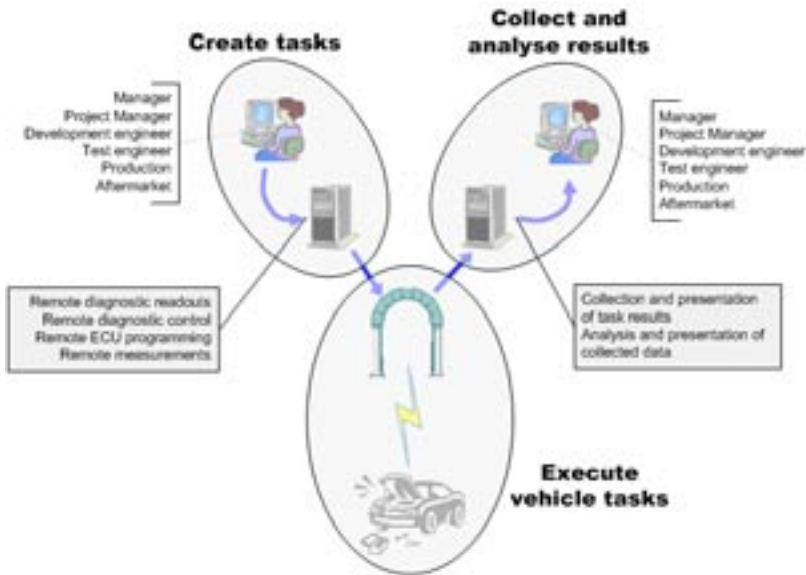

engineer the functionality and results, at the same time as the products competitiveness are increased.

Aim is to create a world leading R&D for diagnostic system for cars ; providing remote diagnostics, remote software download- & analogue data to VCC´s systems for test cars; and to strengthen academic knowledge in the area of safety/security and data mining. A pre-study was carried out by Volvo Cars. Realization is carried out under management from Volvo Cars together with supplier Volvo IT and academies (primarily Chalmers). SIGYN´s research team will cooperate with PhD-students financed by other means, as well as an information exchange e.g. with other V-ICT-pgm.

VISAS – Volvos Infotainment Support Autoliv Safety

Rec.no: 2005-02564

Project Manager: Niklas Adolfsson, Volvo Cars

Duration: 2006-01-01 – 2008-08-08

Total Budget: SEK 30 000 000

Public Funding: SEK 12 930 000

Partners: Volvo Cars, Autoliv Electronics, Chalmers University of Technology

Future telematics platforms must support a wide variety of services, ranging from relatively simple convenience functions, through data sensitive diagnostics services, to time and safety critical short range communication. VISAS aim to explore the possibilities of

such a system for both the car owner and the car manufacturer. VISAS will also set and verify the associated requirements, and on a higher level to create a link between safety and infotainment development at Volvo Cars and Autoliv.

As one example of the merits of short range vehicle to infrastructure communication, also providing a test bed for the communication system, VISAS focus on improving the safety of vulnerable road users (VRUs) in intersections. Chalmers University of Technology leads a scientific study of this subject and will implement a smart intersection that provides drivers with information that could prevent accidents with pedestrians or other VRUs.

A third focus of VISAS is an improved Automatic Emergency Call service, improving both the information content and the methods of distributing important data to emergency services. In order to take a significant step forward, VISAS collaborate with a broad group of representatives of affected organisations and service providers.

Secure & Reliable GPRS Connection on a Pan-European Basis

Rec.no: 2006-00101

Project Manager: Fredrik Callenryd

Duration: 2005-03-15 – 2005-12-31

Total Budget: SEK 11 674 000

Public Funding: SEK 2 918 500

Partners: Scania

There is an increased demand for less expensive communication alternatives on the market. The most talked about alternative today is GPRS, but there are also other alternatives such as 3G/UMTS and WLAN that may eventually prove to be viable alternatives. The properties of GPRS and other IP-based communication are an important requirement for many fleet management applications, and there are several internal projects that depend on its success. Scania Fleet Management portfolio is also includes services that are very communication intensive, for example Order Support and Positioning. To enable volume sales this step in technology development is needed.

This project will introduce GPRS based communication within Scania Fleet Management with a devoted Scania SIM card. This project has been performed during 2005 and is now in phase of introduction in production

Methods for Development of E/E-Systemarchitectures in Early Phases

Rec.no: 2006-00111

Project Manager: Nils-Gunnar Vågstedt, Scania

Duration: 2006-03-15 – 2010-08-30

Total Budget: SEK 5 505 000

Public Funding: SEK 2 750 000

Partners: Scania, Mälardalen University

The E/E system in trucks are becoming increasingly more complex through the introduction of more electronics and software. This trend is expected to proceed, and it pose requirements on the system architecture and methods for designing architectures. The projects aims at surveying challenges and methods for choosing architecture, and then develop new appropriate methods in close cooperation with industry. The methods should together ensure that both aspects of technology and business is considered in the early phases. Since the methods should be a special support in the early phases, uncertainty and risks should be treated by the methods. This is a PhD-project that builds on a previous PhD-project (CODEX) and it will be clustered with a similar project initiated by the Volvo companies (2 PhD-students). The project will support cooperation between industry and academia.

Model Management for Systems Engineering

Rec.no: 2006-00400

Project Manager: Nils-Gunnar Vågstedt

Duration: 2005-03-15 – 2005-12-31

Total Budget: SEK 2 060 000

Public Funding: SEK 1 030 000

Partner: Scania

Model based development is increasingly applied for systems engineering. Models are used to describe and generate software and of course to describe the vehicle itself, i.e. what should be controlled by software. Vehicle models may be used for various purposes, e.g. to simulate fuel economy and other properties while developing new functions (proof of concept), to simulate effects of changes in the software (MIL) or for the verification of the system (HIL). The difficulty is that models are used for various purposes with various requirements, they are developed in various software packages, different parts of the organization develops and uses the models, etc. There are however large

benefits with structured management of models, such as reuse and learning, and the purpose of this project is to develop methods, including interfaces, repository, version management, etc.

ODI – Open Display Interface

Rec.no: 2006-00842

Project Manager: Ingemar Söderlund,
Saab Automobile

Duration: 2005-03-15 – 2006-12-31

Total Budget: SEK 10 854 000

Public Funding: SEK 2 713 500

Partner: Saab Automobile

Functions in a modern car that requires an interface to the driver (and passenger) is increasing at a tremendous pace, including entertainment and information. This interface is almost always based on displays in various combinations of alpha-numeric/graphical, monochrome/colour and of different sizes. This, together with a large number of Electronic Control Units (ECU's) that needs access to the displays, is the main driving factor behind the rapidly growing number of hardware and software variants needed in a modern, well equipped car. All these combinations need their own development, testing and verification that ultimately will consume a lot of time and will also drive the cost to unacceptable levels.

A new approach is taken in the described project to isolate the displays from ECU's by using a standardized communication protocol together with a database acting as a "middleware". This will enable sharing of components and software within GM for all display based products leading to substantially shorter development times, lower development cost and higher quality.

DICO

Rec.no: 2006-00844

Project Manager: Nina Åberg, Volvo Group

Duration: 2005-03-15 – 2005-12-31

Total Budget: SEK 8 310 000

Public Funding: SEK 5 730 000

Partners: Volvo Group, Telia Sonera, Volvo Cars, Chalmers University of Technology, Royal Institute of Technology



The overall purpose of the Dico project is to demonstrate how state-of-the-art spoken language technology can enable access to communication, entertainment and information services as well as to environment control in vehicles. This will be shown primarily by means of working prototypes which promote safety in driving while delivering ease-of-use in access to commercially viable sets of on-line as well as in-vehicle services. The project aims to achieve the following sub-goals:

- Identify, implement and evaluate a selected set of viable applications and services
- Identify, through iterative cycles of user tests, data collection and development, the main user requirements for speech applications in a vehicle environment
- Adapt the dialog system to the vehicle environment with respect to noise, robustness, workload etc.

VERA – Vehicle Electronics Reconfig on Aftermarket

Rec.no: 2006-01598

Project Manager: Nils-Gunnar Vågstedt

Duration: 2006-01-01 – 2007-08-31

Total Budget: SEK 21 092 000

Public Funding: SEK 5 273 000

Partner: Scania

SW and electronics offer improved design and functionality to the Scania products and its business. Today's distribution channel of vehicle parts was not designed for distribution of SW and data. Substantial revenues can be achieved by using the possibility to transfer SW and data digitally between factory systems and vehicles in aftermarket workshops. Project VERA (Vehicle Electronics Reconfiguration After sales) aims at implementing a software platform which will support maintenance of the vehicle electronics on the aftermarket. Pre-development project during 2003 and 2004 led to a suggested technology platform. In aug 2005 this was secured in a 'proof of concept' project. This proposed project covers the implementation of the VERA platform, up to a 'start of production prototype'.

Open Platform for Nomadic Devices

Rec.no: 2006-03433

Project Manager: Ingemar Söderlund, Saab Automobile

Duration: 2006-10-01
– 2007-12-31

Total Budget: SEK 19 674 500

Public Funding:
SEK 10 438 500

Partners: Saab Automobile, Teleca AB, Volvo Technology AB, Appello AB, Scania, Viktoria Institute



The project Open Platform for Nomadic Devices will attempt to solve the problem of connecting and synchronizing nomadic devices to vehicles. The objective is to create a highly flexible software/hardware platform with ability to handle not only existing features and communication protocols like streaming audio using Bluetooth but also future, yet undefined functions and protocols. The platform shall cover a broad spectrum of functions from the simplest to the very complex yet be cost efficient enough to be fitted in a low cost car.

Efficient and Reliable Download of Digital Tacho Data

Rec.no: 2007-00331

Project Manager: Nils-Gunnar Vågstedt

Duration: 2007-02-06 – 2008-08-09

Total Budget: SEK 7 575 000

Public Funding:
SEK 2 581 250

Partner: Scania

The transport operator is obligated to get hold of tachograph (DTCO) data and store this from 1-5 years depending on national legislation. This needs to be done, preferably with as little downtime as possible and as little administrative fuzz as possible in order to full-fill the transporters' needs, which makes the existing solutions today not optimum. With a remote DTCO download service which digitally transfers the log-files from the DTCO and the driver card we will offer the customer the possibility to down-

load data and automatically send this to a central storage system without downtime in operation. The project is performed by Scania, in collaboration with one or more Swedish automotive system supplier.

Flexible HMI Architecture

Rec.no: 2007-01612

Project Manager: Ingemar Söderlund, Saab Automobile

Duration: 2007-05-01 – 2009-06-30

Total Budget: SEK 12 108 000

Public Funding: SEK 5 834 500

Partners: Saab Automobile, Viktoria Institute

The main objective of the project is to develop a flexible HMI architecture that is capable of better handling the increasing magnitude of new functionality enabled by on-board systems as well as nomadic devices. This is important not only to minimize the risk of cognitive load but also to increase vehicle manufacturers' capability to differentiate and scale product offers across different platforms and models.

Addressing the core HMI trends of centralization, differentiation, and scalability in a concerted effort, this collaborative project between GM/Saab Automobile and the Viktoria Institute is intended as a leading edge research effort that eventually may secure future competence and growth in the region. In addition, the project is expected to result in sound knowledge dissemination in the form of intermediate research articles and eventually two licentiate theses at project completion.

Automated Assistance Systems for Efficient Off-board Diagnosis

Rec.no: 2007-01623

Project Manager: Mattias Nyberg

Duration: 2007-09-01 – 2009-11-01

Total Budget: SEK 7 263 000

Public Funding: SEK 2 184 750

Partner: Scania

Diagnosis, on-board as well off-board, is an important task in all automotive systems. The on-board diagnosis systems are developed to detect abnormalities on-board. This information is used in off-board diagnosis (troubleshooting), together with the skills

and knowledge of the mechanic to find and correct the problems. It can be a complicated task for the mechanic to combine all this information. The main target of the project is to develop an automated assistance system that efficiently combines on-board and off-board diagnosis to produce simple guidelines to the mechanic. Optimized troubleshooting leads to gained uptime for the operator, saved money for the workshop, and the vehicle manufacturer will gain a reputation as a producer of reliable and cost effective vehicles. The project will include one senior researcher and one graduate student supported by technical engineers.

Common Product Model for Requirements Management and Model-based Development

Rec.no: 2007-01635

Project Manager: Anna Selmarker, Scania

Duration: 2007-09-01 – 2009-09-01

Total Budget: SEK 8 000 000

Public Funding: SEK 2 250 000

Partners: Scania, Royal Institute of Technology, Chalmers University of Technology

The objective of the project is to make a major contribution to the development of next generation collaborative working environments for vehicle electronics (hardware and software).

The overall aim is to increase creativity, boost innovation and product development efficiency by developing methodology and demonstrators for requirement management and model based development. The current lack of structured requirements management is connected to several problems currently experienced in electronic product development e.g. that one man year was spent on re-work of one specific function due to poor functional descriptions; and that one man year was spent on understanding the ECU (Vehicle computer) requirement when re-designing the ECU. The project will be performed with 3 fulltime scania employees, and two experienced PhD candidates, and two senior researchers from KTH and Chalmers.

NICT – The Network for Vehicle ICT Services for Test Site Sweden

Rec.no: 2007-01640

Project Manager: Anders Fagerholt, Ericsson AB

Duration: 2007-09-01 – 2008-02-29

Total Budget: SEK 1 918 000

Public Funding: SEK 871 000

Partners: Volvo Group, Ericsson AB, Vägverket

Vehicles will be always connected when the level of robustness increases and the cost decreases. Services will enhance safety, security, efficiency, mobility, convenience and entertainment.

Test-Site-Sweden has identified the need of a network for vehicle ICT where innovative services can be created and tested. NICT will investigate a service layer set up for telematics based on the Lindholmen Science Park security arena Mobile Telephony Operator licence and the Government Home Network nodes. The need for additional nodes and features will be investigated. The architecture of NICT will be defined. After a problem and need analysis with the stakeholders an agreement framework for operation of NICT is proposed and the costs for investments and operation assessed. An initial study of interworking of GST, OSGi, CALM and IMS will be made.

SWAP – Software Automotive Platform

Rec.no: 2007-00336

Project Manager: Martin Hiller, Volvo Technology

Duration: 2007-09-01 – 2008-08-31

Total Budget: SEK 24 674 816

Public Funding: SEK 8 494 416

Partners: Consat, ENEA, Mecel, QRtech, Volvo Powertrain, Volvo Car, SAAB Automobile, Systemite AB, Volvo Technology

SWAP will design a state-of-the-art AUTOSAR compliant development and prototyping platform (SWAP platform below), available and useful for a broad range of applied research and product development. Also, SWAP will manage AUTOSAR seminars for increasing the know-how in the region. Through the SWAP platform users get access to a complete state-of-the-art hardware and software platform and a knowledge base allowing them to rigorously tailor their software, tools and other components to

AUTOSAR. The SWAP platform facilitates rapid development of AUTOSAR applications, which makes it more attractive for automotive companies to invest in Sweden. Furthermore, functional safety is becoming an ever increasing requirement. The SWAP platform will be one of the first products to utilize the ISO WD 26262 “Functional Safety-standard” for its development.

SimArch – a General Platform for Driving Simulators and Experiment Systems for Automotive Electronics

Rec.no: 2007-02445

Project Manager: Jonny Vinter, SP

Duration: 2008-01-01 – 2010-06-30

Total Budget: SEK 9 800 000

Public Funding: SEK 4 000 000

Partners: SP Technical Research Institute, Chalmers University of Technology, VTI (Swedish National Road and Transport Research Institute)

Driving simulators for road vehicles are used to evaluate driver behaviour and the three part interaction between driver, basic vehicle models and infrastructure. New technology gives the opportunity to widen the use of driving simulators. Electronic control systems in road vehicles should be tested with a human in the loop in early stages of product development. This is particularly important for active safety systems, where new systems must be tested in a simulator long before real vehicles are available.

The project aims to build a general platform based on the generic SimArch architecture. It will specify standards for communication links and adapt existing components in driving simulators, environment simulators and vehicle models to these standards.

Value Driven Architecture Development

Rec.no: 2007-02773

Project Manager: Ingemar Söderlund, Saab Automobile

Duration: 2007-10-01 – 2009-12-31

Total Budget: SEK 2 717 460

Public Funding: SEK 1 683 730

Partners: Saab Automobile, Chalmers University of Technology

The main objective of this project is to define evaluation criteria relevant for the development and complete life-cycle of an electrical architecture, and how to analyse these criteria at different phases. Analysing these criteria gives an estimate on how “good” the architecture is. This is important because the trend today within the automotive industry is to base a majority of the vehicles on a few common architectures, and as a consequence a lot of cost is tied to those architectures.

The overall goal is to increase the confidence level that the architecture will meet defined requirements and expectations. The project is proposed to be carried out in collaboration between Saab Automobile AB and Chalmers University of Technology. The results are planned to be documented in a Ph D thesis

Robust Vehicle Data Communication

Rec.no: 2007-02774

Project Manager: Ingemar Söderlund, Saab Automobile

Duration: 2007-10-01 – 2009-12-31

Total Budget: SEK 2 736 458

Public Funding: SEK 1 683 729

Partners: Saab Automobile, Chalmers University of Technology

The objective of the project is to study, in the area of robust data communication for future automotive systems, reliability and real-time issues in communication networks that support both time-triggered and event-triggered message transmission. The project is divided into two parts: a work plan towards a licentiate degree and a short list of possible research directions towards a PhD degree after the licentiate degree has been obtained. The work leading to the licentiate degree focuses on understanding the features and limitation of the Flexray protocol, and the development of a reliable communication service on top Flexray that fulfils the needs of different types of applications with varying real-time and reliability requirements.

Further copies of this publication may be ordered from VINNOVA



VINNOVA's mission is to promote sustainable growth by funding needs-driven research and developing effective innovation systems.

VERKET FÖR INNOVATIONSSYSTEM – SWEDISH AGENCY FOR INNOVATION SYSTEMS

VINNOVA, SE-101 58 Stockholm, Sweden • Besök/Office: Mäster Samuelsgatan 56

Phone: +46 (0)8 473 30 00 • Fax: +46 (0)8 473 30 05

VINNOVA@VINNOVA.SE • WWW.VINNOVA.SE